

CONNECT SYSTEMS INC.
1802 Eastman Ave. Suite 116
Ventura, Ca. 93003

Phone (805) 642-7184
Fax (805) 642-7271

Model CS-800

Full Duplex Interconnect

USER'S INSTRUCTION MANUAL
Revised 10/94

Made in U.S.A.

Copyright (C) 1991 By Connect Systems Inc.

TABLE OF CONTENTS

General Description	2
Installation and Adjustments	3
Programming Procedure	8
Operating Mode Programming	9
CW ID Programming	16
Speed-dialer Programming	18
Access code programming	19
OPERATION	21
Placing outgoing calls	22
Incoming calls	23
Options:	
Auxiliary Relay	25
Warranty	26
Appendix A FCC Notice to Users	27
Schematic Diagrams	29-30
Addendum; External Connection Method	31
Glossary	32

GENERAL DESCRIPTION

The Model CS-800 **FULL DUPLEX INTERCONNECT** by Connect Systems Inc. is an economical FULL DUPLEX radio-telephone interconnect terminal. A built-in keyboard and digital display readout allow the user to obtain the maximum power from the on board microprocessor. All features are user programmable and/or selectable.

Powerful built-in standard features such as... 9 number speed dialer, last number redial, remotely controllable relay, automatic disconnect on busy signals and dialtone, fully regenerated tone or pulse dialing, etc. make the CS-800 the best deal going in Full Duplex interconnects today!

Designed and made in the U.S.A.

INSTALLATION AND ADJUSTMENTS

When making up your interface cabling, please use shielded wires with the shields at both ends connected to chassis ground. (The rear panel barrier strip terminals labelled "GND" are chassis ground). We recommend using spade type crimp-on connectors for ease and reliability. Connect the center wires as follows:

AUDIO IN: The audio input terminal may be connected to the discriminator output, or to the high end of the volume control.

Cut JP-1 if connection is made to the high end of the volume control. Leave JP-1 installed if connection is made to the discriminator.

COS: The COS input can be connected to the noise squelch for carrier operation, or to the DPL/CTCSS squelch if you want the radios' built-in decoder to provide private operation.

Noise Squelch Connection: Connect to a point that has considerable voltage swing when the squelch is opened/closed. The best point to connect is to the collector of the transistor that controls the busy (or receive) light (if the radio has one). Otherwise, connect to the output of the noise rectifier.

DPL/CTCSS Squelch: The receiver's DPL or CTCSS decoder will have a logic output that goes high or low when a properly encoded signal is received. Connect this point to the COS input.

If the point selected goes more positive (voltage increases) when a signal is received, leave the factory installed push-on clip on JP-2. If the point goes to a lower voltage, remove the JP-2 clip which will invert the COS signal from the receiver.

When the COS threshold control P5 has been properly adjusted (described below), and the correct polarity selected at JP-2, the front panel RX LED will illuminate when a signal is received, and go out when the signal is removed. **This condition must be achieved for proper operation of the interconnect.**

AUDIO OUT: Connect to the Mic high line. If Mic loading occurs install a resistor in series with the Audio Out lead, and cut JP-3. The resistor should be large enough to prevent Mic loading but small enough to achieve adequate level to mobile audio. Try 100K as a first cut.

PTT: Connect to the transmitter PTT line.

NOTE: Some radios will need the Aux. Relay connected to the hookswitch before the transmitter can be activated. Others may require positive keying voltage. See 'Auxiliary Relay' page 23 for details.

POWER: Connect to a source of 12-14 VDC that can supply up to 300 MA. The CS-800 is reverse polarity protected, so a polarity mistake will not damage your interconnect.

WARNING

The CS-800 contains a power supply sensing circuit that continuously monitors the input supply voltage. An instantaneous drop below 10 VDC will cause a microcomputer reset. If the power supply has poor regulation, erratic operation may result.

The purpose of the input voltage sensor is to protect the non-volatile EE memory during power up and power down.

If erratic operation such as losing calls occurs, be suspicious of poor regulation from the power supply.

#####

ADJUSTMENTS

Initial settings: CCW: P1 P5 **MID ROTATION:** P2 P3 P4 P6 P7

POT PCB Name

Function

P1 RX->L

Mobile to land level: Initially adjust until mobile DTMF decodes as indicated on front panel DTMF LED. Later, adjust for proper mobile level as heard on telephone.

Note: DTMF will not decode unless the RX LED is illuminated indicating that a signal is being received.

P2 L->TX

Land to mobile level: Press the C/D (Connect/Disconnect) switch so that a dialtone is heard. Adjust P2 until the dialtone produces about 3-4 Khz. of modulation deviation. Cut JP-3 if required.

P3 DTMF

Patch to mobile DTMF level: Sets the DTMF transmitter modulation level of land to mobile DTMF and Semi-Duplex privacy beeps.

P4 STATUS TONES

Status beeps & CW ID level: Adjust for desired modulation level of status beeps or CW ID.

P5 COS

COS Threshold level: Measure the voltage at TP-1 with no signal. Then measure the voltage again with a signal applied. Adjust P-5 until the voltage reading at TP-2 is approximately midway between the two readings previously obtained at TP-1.

For example: If TP-1 read 2 volts with no signal, and 4 volts with a signal applied to the receiver, TP-2 would be set to read 3 volts.

When JP-2 is correctly strapped and P5 is properly adjusted, the RX LED will be illuminated when there's a signal and go out when the signal is removed.

P6 RPT AUDIO

Repeat Audio: Sets the modulation level of repeat audio in repeater mode. Adjust only after adjustment of P1 has been completed.

P7 HYBRID BALANCE

See discussion next page.

JUMPER STRAP OPTIONS

- JP-1** De-emphasis strap. De-emphasizes the incoming audio (use when taking audio directly from the FM detector). Cut JP-1 when connecting to a source of flat audio such as the high side of the volume control.
- JP-2** COS polarity select strap. Strap in = non inverted. Remove plastic clip for polarity inversion.
- JP-3** Audio output range strap. Strap in = low level (0-1 V). Strap cut = high level (0-5 V). Strap factory installed.
- JP-4** Selects whether the Aux. Relay output is normally open (NO) or, normally closed (NC). JP-5 is factory strapped for NO. For NC operation, connect the center pad to the NC pad.
- JP-5** Line in use detect strap. Must be installed if the 'line in use' feature is to be used (See programming line 1.2.). Be sure to program line 1.2. with a 0 (to disable) if JP-5 is not strapped.

To enable line in use detect, simply slide the plastic clip off one of the posts, and re-install over both posts. Be sure to program line 1.2. with a '1'.

WHAT IS A HYBRID?

Every telephone has a hybrid (sometimes called a balance network). The purpose of the hybrid is to attenuate the level at which you hear yourself speaking, without affecting your level at the other end or vice-versa.

Various noises in mobile radio communications systems demand that the hybrid in a full duplex terminal should have significantly better performance than a telephone hybrid. Otherwise the duplex mobile would hear excessive return trip audio (echo) and noise. To achieve optimum trans-hybrid isolation, resistive and capacitive nulling (balance) adjustments are required.

When the hybrid is adjusted to produce minimum return trip audio (optimum adjustment) very little of the residual mobile audio will be heard on the system output in comparison to the telephone party audio. But of course the mobile and the telephone party hear each other perfectly.

If semi duplex mode is selected, there is no need to balance the hybrid at all.

HYBRID ALIGNMENT PROCEEDURE

The alignment must take place on the phone line the CS-800 will normally be connected to.

Have a mobile place a call through the CS-800 into a commonly called area. The party answering the called phone should leave the phone off hook during the alignment procedure.

Monitor the transmitter output with a service monitor or connect an oscilloscope to the 'audio out' terminal on the rear of the CS-800. Place all four "HYB comp" dip switches in the off position. See Figure 1.

Have the mobile simultaneously press digits 3 and 6 on his touch tone keyboard. This will result in the transmission of a single 1477 HZ tone. (The front panel DTMF led must not be illuminated during alignment.)

Adjust the "HYB BAL" potentiometer (P7) to produce the least audio output. Switch the "HYB comp" dip switches to the next higher capacitance (see Figure 1) and re-null P7. Repeat this procedure until maximum rejection of the 1477 HZ tone is obtained.

Changes made within the telephone company or re-routing of telephone lines could occasionally require re-adjustment of the hybrid.

	HYB COMP SWITCHES				COMPENSATION
	4	3	2	1	CAPACITANCE
Initial Setting	0	0	0	0	0 uF (min)
	0	0	0	1	.010
	0	0	1	0	.022
	0	0	1	1	.032
increase	0	1	0	0	.050
until	0	1	0	1	.060
optimum	0	1	1	0	.072
null	0	1	1	1	.082
is	1	0	0	0	.100
achieved	1	0	0	1	.110
	1	0	1	0	.122
	1	0	1	1	.132
	1	1	0	0	.150
	1	1	0	1	.160
V	1	1	1	0	.172
Maximum Setting	1	1	1	1	.182 uF (max)

0 = OFF
1 = ON

FIGURE 1

Table of hybrid compensation settings.

PHONE LINE CONNECTION

The CS-800 is equipped with a standard RJ-11 modular phone jack and may be connected to standard ring-tip loopstart CO lines. The following information must be given to the telephone company prior to connecting:

RINGER EQUIVALANCE: 0.6B

In U.S.A.

FCC REG. NUMBER : 2CAUSA - 65702 - OT - E

In Canada

DOC REG. NUMBER : 1755 4558 A

This equipment may not be connected to coin or party lines. Be sure to notify the phone company when discontinuing use. The line in use feature may not be enabled on lines requiring FCC part 68 or DOC registered apparatus. Please see Appendix A at the back of this manual for additional information.

PROGRAMMING THE CS-800

The CS-800 has four easy-access programming areas: 1. Operating Parameters, 2. CW ID, 3. Auto-Dial Phone Numbers, and 4. Access code selection. To enter one of the programming areas, turn the power off, press and hold the corresponding programming area button (No. 1 for Operating Parameters, No. 2 for CW ID, No. 3 for Speed-Dial Numbers or No. 4 for ANI Access Codes) and simultaneously turn on the power. The display will show **0.x.**, where x is the number of the programming button that is being pressed. Release the button, and programming may begin.

Each programming area has the following features in common:

- 1) Programming line numbers are displayed with the dots illuminated on the displays. e.g. **0.1.**, **4.5.** etc.
- 2) Data values are displayed without the dots illuminated. e.g. **00**, **30**, etc.
- 3) Data is entered at a line number by pressing the desired digits followed by the '**P**' key. Consider the '**P**' key as the enter key.
- 4) The GOTO **Any Address** line is displayed as **A.A.** This line is used to branch to any line number in the current programming area. For example, the current line is **A.A.** and you wish to goto line 30. Enter 3 0 P on the keypad and the display will read **3.0**.
- 5) Pressing only **P** at the **A.A.** line will advance the line to **0.1**. Pressing only **P** at any other line will advance to the next available programming line. NOTE: In CW ID, Auto-Dial Phone Number programming, and ANI Access Codes, the next line will be the next numeric line number. In Operating Parameters programming the next line is not necessarily the next numeric line (see the 'Programming the Operating Mode and Parameters' section).
- 6) To view the stored data at a given line number, briefly press **C** on the keypad and then release it. The display will then show the data for a few seconds and then re-display the current line number. Consider '**C**' the 'see' data key.
- 7) At any point during programming, you may return to the **A.A.** line by holding down the **C** key until **A.A.** appears on the display (approximately three seconds).

PROGRAMMING THE OPERATING MODE AND PARAMETERS

(Programming Area No. 1)

To enter the parameter programming mode, press and hold button No. 1 on the internal keypad and then simultaneously turn on the power switch. At this point, the display will read 0.1. When you release the No. 1 button, you will see **A.A.**

A.A. (GOTO Any Address)

Press 'P' to start at line 0.1., or enter the line number you wish to go to and then press 'P'. All line numbers and their associated parameters are listed below starting with REPEATER CONTROLLER PARAMETERS.

Viewing or Changing Parameter Values

A quick tap on 'C' will reveal (for a moment) the currently selected parameter of the displayed program line. If the parameter is acceptable, press 'P' to advance to the next program line, or, enter a new parameter and press 'P' to advance to the next program line.

Parameter Checking

If an out of range parameter is entered (eg. 6 on line 0.1.) pressing 'P' will not cause an advance to the next program line. This prevents you from accidentally entering an unuseable choice.

Returning to A.A.

Programming is finished when you arrive back at A.A. If necessary, you can return to a previously programmed line by holding down 'C' for several seconds. This will return you to A.A. Now enter the line number you wish to return to and press 'P'. Line sequential programming will always flow forward from the current line.

Line numbers shown in braces e.g. [0.8.] indicates where programming will continue after a selection.

When you finish programming, simply turn the power off, and then back on to return to the operate mode.

REPEATER CONTROLLER PARAMETERS

[Branch to]

0.1. Repeater Controller

1 = Enable [0.2.]
0 = Disable [0.8.]
DEFAULT: 0 = Disable

1 - Enable use of the Repeater controller.
0 - Disables the use of the Repeater controller.

0.2. Repeater On/Off Control Code

Enter any three digits: xxx
protocol: #xxx = ON
 ##xxx = OFF
DEFAULT: 456

Select any three digits as an over the air repeater on/off control code. Press # plus the three digits to turn on the repeater. Press ## plus the same three digits to turn off the repeater.

0.3. Repeater Mode CW ID Interval

0 = Disable
Select 1-99 (.1-9.9 minutes)
.1 min increments per step
DEFAULT: 30 = 3 minutes

Choose the CW ID interval that you prefer for repeater mode. Or, disable repeater mode CW ID by pressing 0. The CW ID interval is equal to .1 minutes times the number entered

0.4. Repeater Hang Time

Select 5-99 (.5-9.9 seconds)
Or, Enter 0 for instant dropout. (No courtesy beep)
.1 sec increments per step
DEFAULT: 30 = 3.0 seconds

Selects the time in seconds that the repeater remains on the air after the input signal drops. The time is equal to .1 second times the number entered.

0.5. Repeater Activity Timer

0 = Disable
Select 1-99 (.1 - 9.9 minutes)
.1 minute increments per step
DEFAULT: 5 = .5 minutes

Any single continuous mobile transmission exceeding the repeater activity timer limit puts the repeater off the air. The activity time in minutes is equal to the number entered divided by ten. Pressing 0 disables the activity timer.

0.6. Repeater Courtesy Beep

1 = Enable [0.7.]
0 = Disable [0.8.]
DEFAULT: 1 = Enable

If enabled, the courtesy beep sounds each time a mobile is finished talking. This lets the other mobile know for sure that you have finished and that it's time to respond.

0.7. Courtesy Beep Character

Select 0-37
DEFAULT: 17 = "R"

This choice allows selecting any morse code character from Table 1 (page 17) as the courtesy beep. The default is 17 which sends "R" for roger. If a short beep is desired enter a 4. For a long beep enter 19.

INTERCONNECT OPERATING PARAMETERS [Branch to]

0.8. Interconnect Operating Mode

1 = Semi-Duplex [0.9.]
2 = Full Duplex [1.0.]
0 = Disable [A.A.]
DEFAULT: 2 = Full Duplex

0.9. Semi-Duplex Privacy Mode

1 = Enable
0 = Disable
DEFAULT: 0 = Disable

In privacy mode, the mobile side of the conversation is not re-transmitted. Thus eavesdroppers only hear one half of the conversation. Thus providing some conversation privacy.

1.0. Access Code Remote Programming Code

xxxx = User selectable remote programming code
Protocol: ###xxxx (Enters Remote Programming Mode)
DEFAULT: 9876

Selects the code which is used to enter the remote programming mode. The remote programming mode permits the remote selection or changing of the interconnect access code(s). See Remote Access Code Programming page 18 for more detail.

1.1. Disconnect Code

0 = # Down
1 = # Plus Connect Code
DEFAULT: 0 = # Down

Choose the patch disconnect code. Enter 0 to select # down in most applications. Or enter 1 to select # plus the connect code digits.

1.2. Line in Use Detect

1 = Enable
0 = Disable
DEFAULT: 1 = Enable

When enabled, mobiles are prevented from cutting in on calls that are already in progress on the same line.

NOTE: JP-5 must be strapped for line in use detection to operate. Please refer to page 5 for additional details on Jumper Strap options.

1.3. Five PTT speed-dial

1 = Enable
0 = Disable
DEFAULT: 0 = Disable

If enabled, five presses of the mobile Mic button (at a rate of approximately one push per second) will automatically dial the phone number stored in speed dialer memory location No.1. Five subsequent presses will cause a disconnect.

1.4. Dialing Mode

1 = Tone
0 = Pulse
DEFAULT: 1 = Tone

Select how the CS-800 will dial your phone calls. Note that tone is much faster if you are in a touchtone telephone exchange.

1.5. Access Delay

Select 1-9 (1-9 seconds)
1 sec increments per step
DEFAULT: 2 = 2 secs

Access delay is a user selectable delay to compensate for DTMF-PTT delay built into your mobile microphone. Select a value that allows you to hear all of the CW ID and/or dialtone without clipping.

1.6. Manual Dialing

1 = Enable [1.7.]
0 = Disable [2.2.]
DEFAULT: 1 = Enable

Select disable if dialing should only be allowed from the speed dialer memory.

1.7. Toll Restrict Digit Counting

1 = Enable
0 = Disable
DEFAULT: 0 = Disable

Enables/disables toll restrict digit counting. If enabled, a number exceeding ten digits cannot be dialed.

1.8. Prefix Restrict A

0000 = None (display reads ' -')
x - xxxx = Multi Digit Prefix Restriction
DEFAULT: 1 = 'One' Digit Prefix Restriction (Long Distance)

A 'one' may only be set on this line in order for toll override 1-800 dialing to operate.

1.9. Prefix Restrict B

0000 = None (display reads ' -')
x - xxxx = Multi Digit Prefix Restriction
DEFAULT: 0 = 'Zero' Digit Prefix Restriction (Operator)

2.0. Prefix Restrict C

0000 = None (display reads ' -')
x - xxxx = Multi Digit Prefix Restriction (e.g. 976)
DEFAULT: - = None

2.1. Prefix Restrict D

0000 = None
x - xxxx = Multi Digit Prefix Restriction (e.g. 411)
DEFAULT: - = None

Lines 1.8., 1.9., 2.0., and 2.1. allow selecting any four single digit or multi-digit sequences as restricted. Four digits in sequence maximum. eg. to restrict 0 (operator), 1 (long distance), 976 and 411 enter 1 on line 1.8., enter 0 on line 1.9., enter 976 on line 2.0. and enter 411 on line 2.1.

2.2. Activity Timer

0 = Defeat
Select 10-99 (10-99 seconds)
1 sec increments per step
DEFAULT: 30 = 30 secs

Enter the patch activity timer time directly in seconds or press 0 to defeat. The activity timer is reset by pressing the Mic button at any time.

2.3. Timeout Timer

0 = Defeat
Select 1-99 (.5-49.5 minutes)
.5 minute increments per step
DEFAULT: 6 = 3 minutes

Select the maximum call limit time. The time is equal to .5 minutes (30 seconds) times the number you enter.

2.4. CW ID

1 = CW ID at connect and disconnect.
0 = CW ID at disconnect only.
DEFAULT: 0 = At disconnect only.

After accessing, manual dialing and auto-dialing are delayed until the CW ID is finished if you enter 1.

2.5. Automatic Busy Signal Disconnect

1 = Enable
0 = Disable
DEFAULT: 1 = Enable

2.6. Automatic Dialtone Disconnect

1 = Enable
0 = Disable
DEFAULT: 1 = Enable

2.7. Aux. Relay

0 = Connect [2.9.]
1 = Not Used [2.9.]
2 = Key [2.9.]
3 = Remote Function [2.8.]
DEFAULT: 0 = Connect

0. In connect mode, the relay is on whenever the patch is in connect.
1. No function
2. In key mode, the relay is on whenever the PTT is activated.
3. Remote Function provides a remotely controllable contact closure/opening which can be used for any purpose.

NOTE: Option 801 (Aux. Relay) is required for all the above.

2.8. Remote Function Access Code

xxx = Any three digits
Protocol: #xxx relay ON
 ##xxx relay OFF
DEFAULT: 789

Sets the control code for the Aux. Relay Remote Function. Enter any three digits. To turn on the relay press #xxx. To turn off the relay press ##xxx. This functions only if you entered 3 on line 2.7. Note: Do not operate the remote function while the CS-800 is in connect.

INCOMING CALLS

2.9. Busy Channel Monitor

1 = Enable
0 = Disable
DEFAULT: 0 = Disable

Determines whether the Model CS-800 will ringout or auto-answer if the channel is busy (Enter 0). Or only when the channel is clear (Enter 1).

3.0. Ringout on Ring Number

0 = Disable [3.4.]
Select 1-9 (1-9 ring) [3.1.]
DEFAULT: 1 = First Ring

Selects which incoming ring starts the ringout alert. Enter 1-9 or enter 0 to disable ringout. Ringout is used for receiving ordinary phone calls.

3.1. Ringout Alert

1 = Ring Tone
0 = CW ID
DEFAULT: 1 = Ring Tone

Select whether the ringout alert will consist of a Ring Tone or CW ID. The Ring Tone is similar to a telephone ring. You may also include a DTMF sequence by programming line 3.2.

3.2. Ringout DTMF Sequence

000000 = None (display reads ' -')
x-xxxxxx = DTMF Sequence
DEFAULT : - = None

Enter a 1-6 digit DTMF sequence to be sent during the ringout alert interval. For no DTMF sequence enter 000000.

3.3. Ringout Once or on Alternate Rings

1 = Once
0 = Alternate
DEFAULT: 1 = Once

Only a single ringout alert is allowed in most business radio applications.

3.4. Auto-Answer Ring Number

0 = Disable [A.A.]
Select 1-9 (1-9 ring) [3.5.]
DEFAULT: 0 = Disable

Selects which incoming ring initiates auto-answer. Enter 1-9 or enter 0 to disable. If auto-answer is set to a greater number of rings than ringout, you can have ordinary ringout alerts until auto-answer occurs. After auto-answer, remote base, selective calling or talk back paging can be initiated from any telephone.

3.5. Telephone Remote Base

0 = Disable [3.6.] **NOTE:** Enter "0"
1 = Automatic on Auto-answer [3.8.] if tone signaling
2 = Access Code Required [3.8.] is to be used with
DEFAULT: 0 = Disable remote base mode.

Enter 0 if remote base operation is not desired or if DTMF selective calling or DTMF talk-back paging is to be used. Enter 1 if remote base operation should automatically occur after auto answer. Enter 2 if an access code should be required from the initiating phone after the auto-answer beep to engage remote base operation. (Use the same access code used by mobiles).

NOTE: There can be no DTMF selective calling if choice 1 or 2 has been made. The operation section will explain how to have DTMF selective calling and Remote Base Mode combined.

IMPORTANT: The following line numbers are not used. Each line number has a default value shown which must not be changed. DO NOT PROGRAM LINE NUMBERS 3.6. OR BEYOND.

3.6. = 1
3.7. = 8
3.8. = 0
3.9. = 6
4.0. = 1
4.1. = 0
4.2. = 0
4.3. = 0
4.4. = 0
4.5. = 1
4.6. = 33
4.7. = 1

PROGRAMMING THE CW ID
(Programming Area No. 2)

To enter the CW ID programming mode, press and hold button No. 2 on the internal keypad and then simultaneously turn on the power switch. At this point, the display will read 0.2. When you release the No. 2 button, you will see **A.A.**

A.A. (GOTO Any Address)

Press 'P' to start at character position 0.1., or enter the character position number you wish to go to and then press 'P'.

Viewing or Changing Character Codes

A quick tap on 'C' will reveal (for a moment) the currently selected character code for the displayed character position. If the character code is acceptable, press 'P' to advance to the next character position, or, enter a new character code and press 'P' to advance to the next character position.

Character Code Range Checking

If a number greater than 38 is entered, pressing 'P' will not cause an advance to the next character position. This prevents you from accidentally entering an unuseable choice.

Returning to A.A.

If desired, you can return to a previously programmed character position by holding down 'C' for several seconds. This will return you to A.A. Now enter the character position (line number) you wish to return to and press 'P'.

PROGRAMMING

The CW ID message sent from the CS-800 may consist of up to 15 characters. To program the message, enter the desired character codes (from Table 1 page 17) starting at character position **0.1.** thru the length of the string. If the message is less than 15 characters, it must be terminated with code 38 (Message End). For example, to program the CW ID message 'CSI':

- 0) Enter CW ID Programming Mode as explained above (Hold down key No. 2 and switch on the power)
- 1) From the **A.A.** line hit 'P'
- 2) From **0.1.** enter: ' 2 P' for the character "C"
- 3) From **0.2.** enter: '18 P' for the character "S"
- 4) From **0.3.** enter: ' 8 P' for the character "I"
- 5) From **0.4.** enter: '38 P' to end the message.
- 6) Turn off the power, and then back on, to return to operate mode with the newly programmed CW ID message.

TABLE 1 CW ID CHARACTER CODES						
A = 0	G = 6	M = 12	S = 18	Y = 24	5 = 30	WORD
B = 1	H = 7	N = 13	T = 19	Z = 25	6 = 31	SPACE= 36
C = 2	I = 8	O = 14	U = 20	1 = 26	7 = 32	
D = 3	J = 9	P = 15	V = 21	2 = 27	8 = 33	SLANT
E = 4	K = 10	Q = 16	W = 22	3 = 28	9 = 34	BAR = 37
F = 5	L = 11	R = 17	X = 23	4 = 29	0 = 35	
						MESSAGE
						END = 38
e.g. CW ID message desired is 'CSI' Enter 2, 18, 8, 38						

SPEED DIAL PHONE NUMBER PROGRAMMING

(Programming Area No. 3)

To enter the speed dial phone number programming mode, press and hold button No. 3 on the internal keypad and then simultaneously turn on the power switch. At this point, the display will read 0.3. When you release the No. 3 button, you will see A.A.

A.A. (GOTO Any Address)

Press 'P' to start at speed dialer location 0.1., or enter the speed dialer location you wish to go to, then press 'P'.

There are ninety memory locations available to store your favorite phone numbers. These are 0.1. through 9.0. When using these memory locations from the mobile, they become simply 1-90. Locations 1-16 can store phone numbers up to fifteen digits, locations 17-90 are limited to a length of eight digits.

Viewing or Changing Phone Numbers

A quick tap on 'C' will reveal the phone number stored at the currently displayed memory location. The phone number is displayed digit by digit until all digits in the number have been shown. If the phone number is acceptable, press 'P' to advance to the next location. Or, enter a new phone number and press 'P' to advance to the next location. Any memory can be erased by entering three zeros. (000P).

NOTE: If there is no number at the current location, pressing 'C' will flash the current location number once instead of showing a phone number.

Programming *, Pause or #

The No. 1, 2 and 3 keys on the keypad are used as dual input keys. To program a phone number which contains any of these digits, briefly press the key and continue with the number, as you would with any other digit. To program a *, press the No. 1 key until a single bar '|' is added to the display (approx. 3 seconds) then release the key. To program a pause, press the No. 2 key until a dash '-' is added to the display. To program a #, hold down the No. 3 key until a double bar '||' is added to the display.

Returning to A.A.

If desired, you can return to a previously programmed auto-dial location by holding down 'C' for several seconds until A.A. shows on the display. Now enter the speed dial location you wish to return to and press 'P'.

Returning to Operate

To return to normal operation, switch off the power and then back on. You can now use your newly programmed speed dial numbers!

Access Code Programming

(Programming Area No. 4)

Two separate 1-6 digit interconnect access codes can be programmed from the keyboard or over the air remotely. * up is the default access code. We suggest not changing this code until you have the CS-800 fully up and running.

The codes selected can be any combination of digits, six maximum. Codes beginning with odd numbers have toll override capability. Codes beginning with even numbers must abide by the toll parameters programmed on lines 1.7.- 2.1.

When accessing the CS-800 from the mobile, the selected code(s) must be preceded by *. To disconnect, press #, or # plus the connect code digits if a 1 was entered on line 1.1.

Examples of connect codes:

- *657 Regular Access Code
- *2 Regular Access Code
- *7214 Toll Override Access Code
- *313 Toll Override Access Code

Programming Access Codes From The Keyboard

Programming access codes from the keyboard is very similar to programming phone numbers into the Speed-Dialer memory. Simply hold down the number 4 button and turn on the power. The display will read A.A. Press P and the display will read 0.1. You may now enter any desired access code followed by P. The display will now read 0.2. You may now enter a second access code followed by P. An access code can be erased by advancing to the line where the undesired code resides and entering three zeros (000) followed by 'P'.

The regular access code is usually programmed on line 0.1. and the secret toll override code on line 0.2. However the order is not important. Remember that regular access codes begin with an even number and toll override codes begin with an odd number.

The CS-800 can only be returned to simple * up operation by programming a 0 on line 0.1. (If a 0 is programmed on line 0.2. it will be interpreted as being the access code *0.)

To return to normal operation, switch off the power and then back on. You can now access the interconnect using your newly programmed access codes.

Programming Access Codes Over The Air

Access codes can be added or deleted over the air. (Hereafter called editing).

To edit an access code, you must follow three steps...

1. Enter the remote programming mode by pressing # three times followed by the remote programming code selected on line 1.0. For example: ###9876

2. Enter a 1-6 digit access code followed by * to enable a code. To delete a code, enter the access code you wish to disable followed by #.

3. Exit the access code programming mode by pressing # three times (###).

Example: You wish to change an access code from *321 to *7592.
Enter in this order: ###9876 321# 7592* ###.

NOTE: If a code other than 9876 was entered on line 1.0., use that code to enter the remote programming mode instead of 9876 as used in the example.

OPERATION

The CS-800 will momentarily display all DTMF digits on the internal display as they are decoded. This is a useful feature to make sure that DTMF tones are decoding properly.

NOTE: The DTMF digits * and # are shown on the internal display as a '| ' and '| |' respectively (same as 'p' and 'c' on the internal keypad). This is because the displays used can not display the * and # symbols.

PLACING OUTGOING CALLS

DIALING A CALL MANUALLY: From the mobile press *, or * plus one of the access codes that was selected in programming area 4. If the access delay on line 1.5. is properly set, you will hear dialtone or CW ID start without clipping or delay. You may dial as soon as dialtone is heard.

After dialing, the next thing heard will either be ringing or a busy signal. The CS-800 will automatically disconnect if the number that was called is busy. (2.5.).

TOLL RESTRICT: Four sets of restricted leading digit sequences can be set to restrict dialing to certain numbers and/or prefixes. These selections are made on user programming lines 1.8. - 2.1.

Remember, that access codes beginning with odd numbers have toll override capability and can dial any number. While access codes beginning with even numbers are restricted per your programming.

1-800 DIALING: The CS-800 will allow dialing to toll free 1-800 numbers even if 1 is set as a restricted first digit. However, if you are going to restrict 1, you must restrict it on programming line number 1.8.

CALL WAITING: If line in use detection has been enabled, (1.2), the CS-800 checks to see if the line is in use when a mobile attempts access. If the line is free the mobile will hear dialtone and can proceed with his call. If the line was in use, the CS-800 will send a special busy signal to the mobile and revert to the stand-by condition. At the same time, Call Waiting beeps let those using the line know that a mobile unit would like to use the line. When the telephone users hang-up, beeps let the mobile know that the line is now free to use.

The mobile can cut-in on the call if desired by using a toll override access code after hearing the line in use busy signal. A three way conversation can now take place.

NOTE: The line in use enable strap JP-5 must be installed for line in use detect to operate. See page 5 for information about jumper straps.

PROGRAMMING THE SPEED DIALER FROM THE MOBILE: Writing a phone number into the speed dialer memory from the mobile is accomplished with a slight variation on ordinary manual dialing. Before you enter your access code, send 9 followed by the desired memory location number. e.g. You wish to place a call to 277-1463 and simultaneously add the number to speed dial memory location 6. From the mobile, enter 9 6 then the access code. When the dialtone is heard, dial 277-1463 just as you would in ordinary manual dialing. You will never have to manually dial 277-1463 again!

NOTE: The 9 as used above means **WRITE** the phone number to be dialed into the memory location specified immediately following the 9.

PLACING A CALL WITH THE SPEED DIALER: Once a phone number has been stored, calling back is a snap! Simply precede the access code with the appropriate memory location number. Soon, your intended number will be ringing. Example: Your access code has been set as * only. You wish to call a friend whose phone number has been previously stored in location 4. Simply enter 4 * on your mobile keypad. Another example: Your access code is *291, and you wish to speed dial the number in memory location No. 7. Enter 7*291, thats all there is to it!

NOTE: If you attempt to speed dial from a memory location that has not been previously loaded, the CS-800 will send an error message consisting of a string of eight beeps, and then return to the stand-by condition.

LAST NUMBER REDIAL: The last phone number called is always automatically stored at speed dial memory location NO. 0. To redial the last number called, simply precede the access code with 0. Similar to using the speed dialer. e.g. 0*, 0*291 etc.

HOOK FLASH: The CS-800 has a built-in precise 570 MS hook flash to operate certain phone company provided features such as call waiting. To flash, simply press * three times (***) .

NOTE: The 570 ms. on-hook flash can cause a disconnect on some phone lines.

ACTIVITY TIMER: Once your number has been dialed, the activity timer starts operating. A warning beep is heard every two seconds during the second half of the programmed timeout interval. Beeps warn of impending timeout.

The activity timer is constantly reset while the mobile is transmitting, and starts timing when the mobile stops transmitting. Upon hearing timeout warning beeps, a brief press of the mobile Mic button resets the activity timer. Failure to reset will result in a disconnect.

Note: when using in full duplex (mobile constantly transmitting) the mobile activity timer is always reset and the timeout beeps will not be heard. However the activity timer will cause automatic disconnect if the mobile forgets to send the disconnect code when finished, or if the mobile drives out of range.

TIMEOUT TIMER: Calls will automatically disconnect at the end of the time you selected on line 2.3. Two quick beeps heard in succession every two seconds during the final twenty seconds warn that time out is imminent. The timeout timer can be reset by the mobile by pressing *.

DISCONNECTING WHEN THROUGH: If a "0" was entered on line 1.1. simply press # to disconnect. If a "1" was entered, press # plus the connect digits that were used to connect.

FIVE PRESS AUTO DIAL: If a "1" was entered on line 1.3., the phone number residing in memory location No. 1 can be automatically dialed by pressing the mobile Mic button five times in succession. When the call is finished, five more presses will cause disconnect.

If you press too fast or too slow the CS-800 will not respond. The correct rate is about one press per second. This timing is required to keep rapid mobile fading and normal on channel Mic button pressing from falsing the patch on and/or off.

INCOMING CALLS

RINGOUT: Lines 2.9. through 3.3. allow you to customize ringout for your application. Ringout is how the Model CS-800 alerts you to the presence of an incoming call.

When a call comes in, the Model CS-800 first checks to see if the channel is in use (2.9.). The incoming rings are counted (3.0). before a mobile alert is sent. The alert can consist of a Ring Tone that sounds like a telephone ringing or a CW ID (3.1.) The alert can also be prefaced by a sequential DTMF sequence (3.2.) The user programmable DTMF sequence (3.2.) can be used to operate attention getters such as a horn honker. The type of alert selected can be set to occur only once or on alternate rings (3.3.) of the incoming call.

To answer your call from the mobile, simply enter your access code. When you complete your call, send the disconnect code.

AUTO ANSWER: The Model CS-800 must be set to automatically answer (3.4.) incoming calls if you wish to use the Remote Base and or Selective Call modes.

NOTE: If ringout is set to occur earlier in the ring cycle (3.0.) than auto answer (3.4.), it is possible to receive ordinary incoming calls plus use the modes which require an auto answer.

TELEPHONE REMOTE BASE: You can dispatch and have full use of your system from any telephone by entering a 1 or 2 on (3.5.)...

Enter 1 if you would like to access your radio system from any phone without the need to enter the system access code. Or, if you wish to dispatch from dial pulse phones.

Enter 2 if you would like the additional security of having to enter the system access code (1.4.) after the auto-answer beep.

You can call any mobile or portable on the system. Whether they are equipped with DTMF or not.

When your dispatch is finished, send the disconnect code before you hang-up. If you forget, built-in safe-guards such as call progress tone detection will keep the Model CS-800 in control. Fully automatically!

SELECTIVE CALLING: Any mobile or portable radio equipped with a DTMF decoder can be selectively called from any touchphone. After the auto-answer beep, enter the appropriate selective call digits followed by *. (The * is not sent)

For example: XXXXX* (x's any length, any sequence)

The Model CS-800 will hold the auto answered call for thirty seconds giving the mobile time to respond. To answer a call and activate two way voice capability, the mobile must send the connect code. When the call is completed, the mobile should send the disconnect code.

REMOTE BASE WITH SELECTIVE CALLING: Remote Base with selective calling can be accessed by entering the connect code after the auto-answer beep. You can then send a DTMF selective call code by entering the appropriate digits followed by *. (Remote base mode 3.5. must be set to 0 if selective calling is to be used).

Example: You've selected *7 as your access code and you wish to send the selective call code 639. After the auto answer beep enter *7 639*.

CALL PROGRESS TONE DETECTION The Model CS-800 incorporates very sophisticated software algorithms that automatically sense the presence of dialtone and/or busy signals. The method used will function with any tone frequencies. There is nothing to adjust or maintain, it's completely automatic!

Note: On lines 2.5. and 2.6. you can selectively enable or disable busy signal disconnect and dialtone disconnect for special applications.

AUXILLIARY RELAY

Option 801

Relay Switched PTT: If the radio's unkeyed PTT voltage exceeds 16 VDC or if inverted keying is required (closure to 12V) the auxiliary relay must be used to key the transmitter.

Enter 2 (KEY) on line 2.7. Connect the radio's PTT line to one of the Aux. Relay contacts (CONT1 or CONT2) on the barrier strip. Connect the other Aux. Relay contact to 12 VDC. Make sure JP-4 is strapped from the center to the NO position. The PTT connection on the barrier strip should not be connected.

Remote Relay Function: In some installations it may be desirable to remotely control (switch) something from the mobile. e.g. change channels, change CTCSS tones, change antennas etc.

Enter 3 (REMOTE FUNCTION) on line 2.7. Then select a three digit control code on line 2.8. If the code selected was 789, you would turn on the Remote Relay by sending #789. To turn off the relay send ##789.

CONNECTING THE RELAY

Connect the device requiring remote control to the two terminals labeled CONT1 and CONT2 (CONT means control) on the rear panel barrier block. The CS-800 is supplied with the relay strapped for normally open operation. If normally closed operation is desired, see JP-4 on page 5 for details.

LIMITED WARRANTY

Connect Systems Inc. (CSI) hereby warrants our products to be free from defective workmanship for a period of one year and defective parts for a period of five years from date of sale to the initial end user. This warranty applies only to the original consumer/end user purchaser of each CSI product. During the first year of warranty, CSI will repair any of its products at no charge providing the defective unit is shipped prepaid and service is performed by CSI. During the years 2 -5, there shall be no charge for replacement parts providing that the defective unit is shipped prepaid and service is performed by CSI. Conventional prevailing labor and shipping charges will apply following the end of the first year. CSI, at its sole discretion, will replace defective parts on an exchange basis for the first five years of ownership by the original purchaser. All shipping cost are the responsibility of the customer.

What is not covered by this limited warranty:

This warranty shall not apply, if, in our judgment the defects are caused by misuse, lightning strikes, customer modification, water damage, negligent use, improper installation, overloads caused by external voltage fluctuations, use of unregulated power supply, damage caused by transit or handling or an abusive treatment not in accordance with ordinary product use or the product serial number has been removed, altered, or defaced.

THIS WARRANTY IS IN LIEU OF ALL OTHER WARRANTIES, STATEMENTS OR REPRESENTATIONS, AND UNLESS STATED HEREIN, ALL SUCH WARRANTIES, STATEMENTS OR REPRESENTATIONS MADE BY ANY OTHER PERSON OR FIRM ARE VOID. ALL IMPLIED WARRANTIES IN CONNECTION WITH THE SALE OF THIS EQUIPMENT, INCLUDING THE WARRANTY OF MERCHANTABILITY, SHALL BE OF THE SAME DURATION AS THE WARRANTY PERIOD STATED ABOVE. SOME STATES DO NOT ALLOW LIMITATIONS OF HOW LONG AN IMPLIED WARRANTY LAST, SO THE ABOVE LIMITATION MAY NOT APPLY TO YOU. IN THE EVENT OF PRODUCT FAILURE WHICH PROVES TO BE CAUSED BY A DEFECT IN WORKMANSHIP OF MATERIALS, YOUR SOLE REMEDY SHALL BE THE REPAIR OF THE DEFECT BY CSI OR ITS APPOINTED REPAIR STATION AS STATION AS STATED IN THIS WARRANTY, AND UNDER NO CIRCUMSTANCES SHALL CSI BE LIABLE FOR ANY LOSS OR DAMAGE, DIRECT, INCIDENTAL, OR CONSEQUENTIAL, ARISING OUT OF THE USE, OR INABILITY TO USE, THIS PRODUCT. SOME STATES DO NOT ALLOW THE EXCLUSION OR LIMITATION OF INCIDENTAL OR CONSEQUENTIAL DAMAGES, SO THE ABOVE LIMITATION OR EXCLUSION MAY NOT APPLY TO YOU.

If your new CSI product shall ever fail, contact Connect Systems Inc. Customer Service Dept. for repair and warranty information at (805) 642-7184

Note: Connect Systems Inc. reserves the right to render a modest service charge when returned units are found to be free of parts or workmanship defect(s) (i.e. operating to factory specification) within the first year of warranty. Such units will be returned freight collect to the sender, including the appropriate service charge.

APPENDIX A

FCC NOTICE TO USERS

1. This equipment complies with part 68 of the FCC rules. On the bottom of this equipment is a label that contains, among other information, the FCC registration number and ringer equivalence number (REN) for this equipment. If requested, this information must be provided to the telephone company.
2. The REN is used to determine the quantity of devices which may be connected to the telephone line. Excessive REN's on the telephone line may result in the device not ringing in response to an incoming call. In most, but not all areas, the sum of the REN's should not exceed five (5.0). To be certain of the number of devices that may be attached to the line, as determined by the total REN's contact the telephone company to determine the maximum REN for the area.
3. If this product causes harm to the telephone network, the telephone company will notify you in advance that temporary discontinuance of service may be required. But if advance notice isn't practical, the telephone company will notify the customer as soon as possible. Also, you will be advised of your right to file a complaint with the FCC if you believe necessary.
4. The telephone company may make changes in it's facilities, equipment, operations, or procedures that could affect the operation of the equipment. If this should happen, the telephone company will provide advance notice in order for you to make the necessary modifications in order to maintain uninterrupted service.
5. If trouble is experienced with this product, please contact Connect Systems Incorporated at (805) 642-7184 for repair and warranty information. If the trouble is causing harm to the telephone network, the telephone company may request you remove the equipment from the network until the problem is resolved.
6. There are no repairs that can be accomplished by the user. In the event of operation problems, disconnect your unit by removing the modular plug from the telephone company modular jack. If your regular telephone still works correctly, your unit has a problem and should be returned for repairs (in or out of warranty). If upon disconnection of your unit there is still a problem on your line, notify the telephone company that they have a problem and request prompt repair service. The unit may be returned to Connect System Incorporated, 2064 Eastman Ave, Suite #113, Ventura, CA 93003.

7. This interconnect product cannot be used on a public coin service provided by the telephone company. Connect to Party Line Service is subject to state tariffs. Contact the state public utility commission, public service commission or corporation commission for information.
8. This device complies with part 15 of the FCC rules. Operation is subject to the following two conditions: (1) This device may not cause harmful interference, and (2) This device must accept any interference received, including interference which may cause undesirable operation.
9. This equipment generates and uses radio frequency energy and if not installed and used properly, i.e. in strict accordance with the service manual, may cause interference to radio or television reception. It has been tested and found to comply with the limits for a Class B computing device pursuant to Subpart J of Part 15 of FCC rules, which are designed to provide reasonable protection against such interference when operated in a residential installation.
10. If this equipment does cause interference to radio or television reception, which can be determined by turning the equipment off and on, the user is encouraged to try to correct the interference by one or more of the following measures:
 - a. Reorient the receiving antenna.
 - b. Relocate the equipment with respect to the receiver.
 - c. Move the equipment away from the receiver.
 - d. Plug the equipment into a different outlet so that equipment and receiver are on different branch circuits.
 - e. Ensure that card mounting screws, attachment connector screws, and ground wires are tightly secured.
 - f. If cables not offered by this company are used with this equipment, it is suggested that you use shielded, grounded cables with in line filters, if necessary.
 - g. If necessary consult your dealer service representative for additional suggestions.
11. The manufacturer is not responsible for any radio or TV interference caused by unauthorized modifications to this equipment. It is the responsibility of the user to correct such interference.

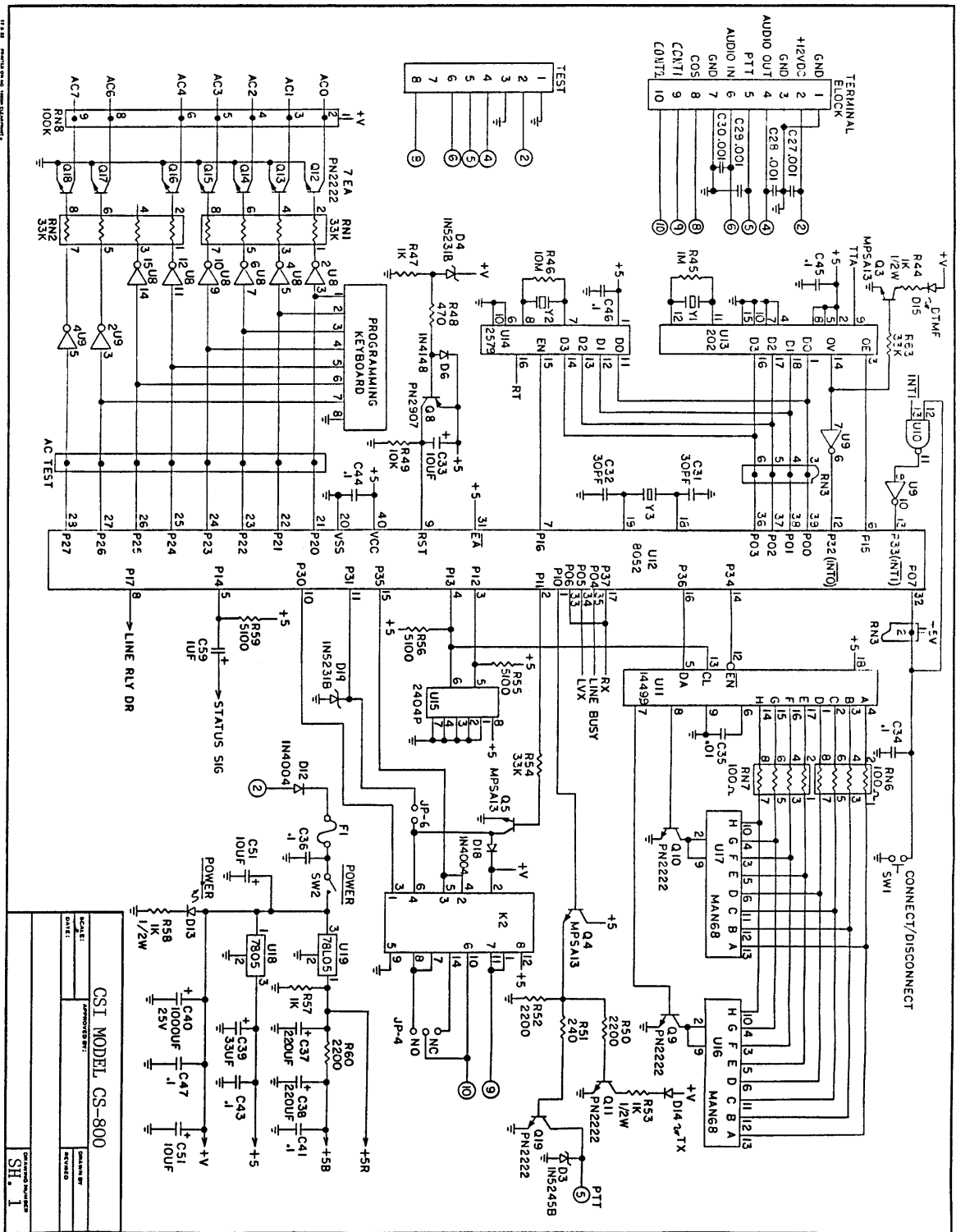

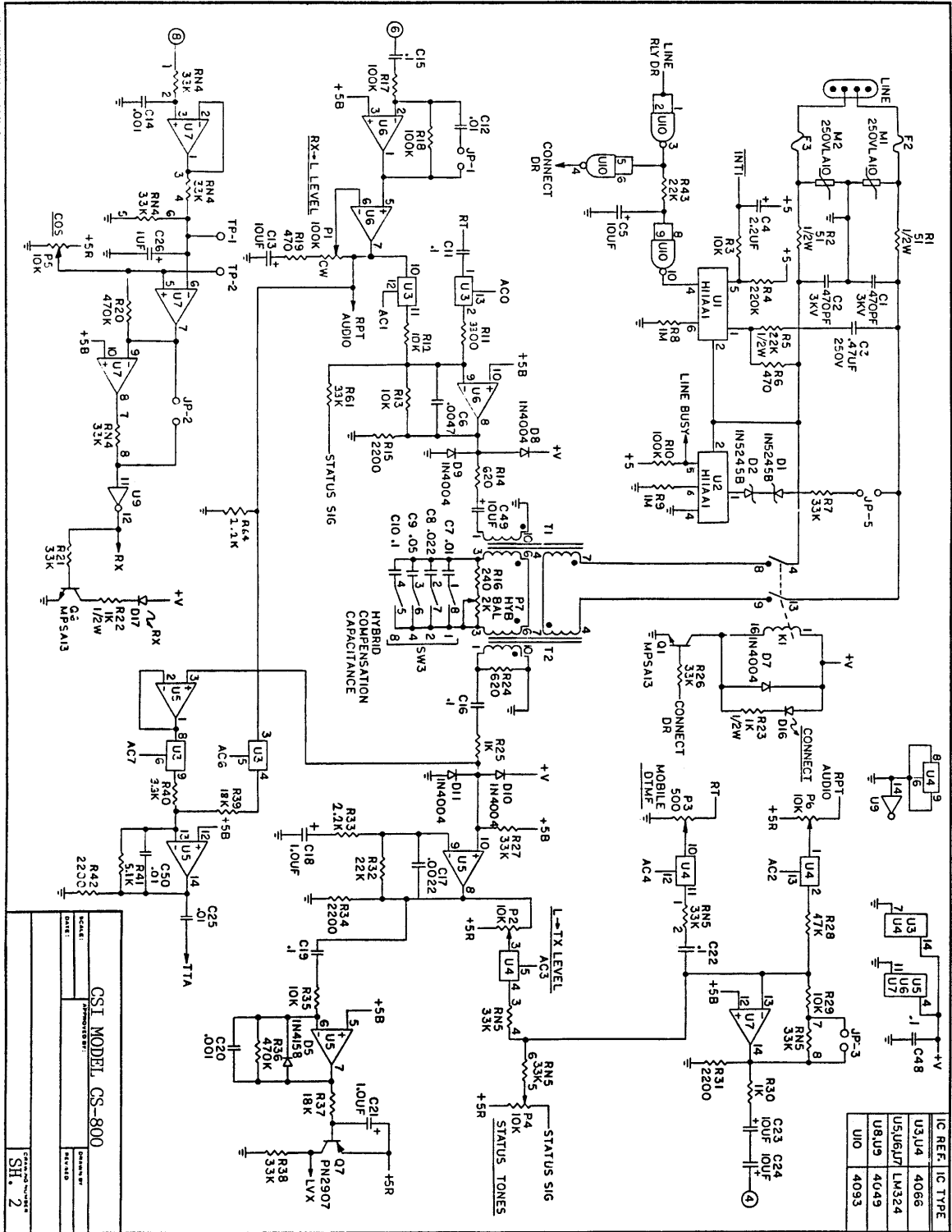

ADDENDUM

External Connection Method

The CS-800 can be connected to the Mic. and external speaker or earphone jack of your duplex radio if you are willing to have a few features which can not operate. Those using the CS-800 in the amateur radio service may find this method entirely satisfactory. Simply connect the Earphone or Speaker output to the AUDIO IN. Connect the Mic. lead to the AUDIO OUT. Connect the PTT lead to the PTT on the CS-800.

Since the audio will be taken from the speaker leads, the volume control must be preset and may not be changed. Set the RX->L control (P1) to fully CCW. Use the radios' volume control to set the mobile to land audio level. The volume control must now be left in this position.

Also, when connected externally there will be no COS connection. Therefore the interconnect will not know when the mobile is transmitting. This forces you to make the following programming choices:

0.1. Must be set to 0. The repeater controller cannot be used without a COS connection.

0.8. Must be set to 2. The interconnect can only operate in Full Duplex without a COS connection.

1.3. Must be set to 0. Five PTT Autodial cannot be used with a COS connection.

2.2. Must be set to 0. The activity timer feature cannot be used without a COS connection.

2.9. Must be set to 0. The CS-800 cannot tell if the channel is in use without a COS connection.

Finally, the CS-800 must be set up so that it thinks the mobile is always transmitting. The following steps must be taken:

1. The COS input must be connected to one of the GND terminals with a piece of wire.

2. The COS control (P5) must be set to mid rotation. (Setting is not critical).

3. Remove the plastic shorting clip from JP-2.

If these steps have been properly executed, the front panel REC LED will always be illuminated. The CS-800 will now operate in full duplex mode with the limitations outlined above.

GLOSSARY

COS	Carrier Operated Squelch
DCS	Digital Coded Squelch
CTCSS	Continous Tone Coded Squelch System
JP	Jumper (Schematic designator)
CCW	Counter Clockwise
POT	Potentiometer
PCB	Printed Circuit Board
CW ID	Continous Wave Identification (International Morse Code)
FCC	Federal Communications Commission (USA)
DOC	Department of Communications (Canada)
CO lines	Central Office Lines (telephone lines from phone company)
ANI	Automatic Number Identifcation
DTMF	Dual Tone Multi-Frequency (touch tone dialing format)
PTT	Push to Talk (tranmitter keying using microphone switch)