

**CS4000 AND CS4001 USERS MANUAL**

**FM HANDHELD TRANCEIVER**

**CONNECT SYSTEMS INCORPORATED**

**1802 Eastman Ave., Suite 116**

**Ventura CA 93003**



**VERSION 1.00**

Copyright 2010 by Connect Systems Incorporated

## GUIDE FOR THOSE THAT DO NOT LIKE TO READ MANUALS

**You have eight items in your box as follows:**

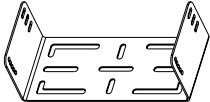
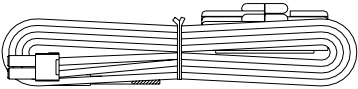
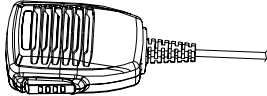
Radio  
Fixed Bracket  
Power Cable  
Hand Microphone  
Microphone Hanger  
M4\*10 Combination Screw (quantity 4)  
M4\*16 Self-tapping Screw (quantity 2)  
M5\*16 Self-tapping Screw (quantity 4)

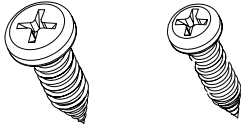
 Fixed bracket	 Power Cable	 Hand Microphone
 Microphone Hanger	 M4*10 Combination Screw	 M5*16 / M4*16 Self-tapping Screw

### **SETTING UP THE RADIO**

Please use the service of a qualified radio technician as it involves attaching an external antenna to the antenna jack and requires connecting the power cable to the car battery through some protection device.

### **USING THE RADIO**

Press the PTT switch on the hand microphone to talk and release to listen. Change channels as necessary.

Wasn't that easy!

**NOW PLEASE READ THE REST OF THE MANUAL SO YOU WON'T KILL YOURSELF OR A CO-WORKER AND DAMAGE THE RADIO.**

## **Thank You**

We are very grateful for you purchasing the Connect Systems Inc. brand professional two-way radio. This radio incorporates the latest technology and can bring great convenience to your life and work. The quality and function of this radio will meet your demands for reliable communication.

## **Models Covered By This Manual**

- CS4000 UHF FM Mobile Transceiver
- CS4001 VHF FM Mobile Transceiver

### **Notices To The User**

- Government laws under the FCC regulations prohibits radio communication with this radio without being licensed.
- Unlicensed use is illegal and subjects the user to punishment by fines and/or imprisonment.
- If this radio needs service, contact a qualified technician.

### **General Warnings**

**Do not use your radios under the following circumstances:**

- In the presence of potentially explosive atmospheres such as gas stations.
- While being in any location where there is gasoline or other types of fuels.
- In or near a site using explosives.
- In a location where there is a potential for explosion because of the environment such as grain elevators.

## **Warning on Danger of Radio Frequency and Magnetic Energy**

The Model CS4000 and CS4001 generates both radio frequency energy and magnetic energy while transmitting. Any transmitter has the potential to cause heating and other thermal effects in your body. The amount of heating and other thermal effects is determined by the power out from the radio and the distance from the body. To minimize exposure the radio frequency energy and magnetic energy the user should use the radio the minimum time required to achieve satisfactory communication, use minimum power, and keep the radio as far away as possible.

This radio is classified as “Occupational Use Only”. That means the user of the radio is aware of the potential hazards of using radios and is in a position to and familiar with ways to minimize the hazards. This radio should not be used by the general public because the general public has no knowledge of the hazards of two way radios and how to minimize risk and might not be in a position to minimize those risks.

**To minimize exposure to radio frequency energy and magnetic energy, the following list should be observed:**

- When the PTT (push to talk) switch is pressed and you are transmitting, keep the antenna away from any part of your body or the body of any bystanders. Normally this is not a problem because the radio is in the vehicle and the antenna is on the outside of the vehicle
- Keep the transmission time to a minimum. Normal operation of a radio of this type is five percent transmitting, five percent receiving, and the rest of the time in standby mode. Any amount in excess of fifty percent of the available time in transmit mode is considered excessive and should be avoided.
- Use only an external antenna attached to the outside of the vehicle.

## **Other Warnings on Operation of the Radio**

- Do not expose the radio to long periods of direct sunlight or place the radio too close to a heating appliance.
- Do not place the radio in excessively dusty areas, humid areas, or on an unstable surface.
- Do not modify this radio for any reason.
- Have this radio serviced only by a qualified technician.
- If the radio emits smoke or strange odors, immediately turn off the radio and then contact your local authorized service dealer.
- This radio is not designed to work underwater. If your radio is in your vehicle and it is underwater you might have serious problems such as breathing.
- While this radio is waterproof, please keep windows closed during heavy rains.

## **FCC Warnings**

This equipment generates or uses radio frequency energy. Changes or modifications to this equipment may cause harmful interference unless the modifications are expressly approved in the instruction manual. The user could lose the authority to operate this equipment if an unauthorized change or modification is made.

This equipment has been tested and found to comply with the limits for a Class B digital device, pursuant to Part 15 of the FCC rules. These limits are designed to provide reasonable protection against harmful interference in a residential installation.

This equipment generates, uses and can generate radio frequency energy and, if not installed and used in accordance with the instructions, may cause harmful interference to radio communications. However, there is no guarantee that the interference will not occur in a particular installation. If this equipment does cause harmful interference to radio or television reception, which can be determined by turning the equipment off and on, the user is encouraged to try to correct the interference by one or more of the following measures:

- Reorient or relocate the receiving antenna.
- Increase the separation between the equipment and receiver.
- Connect the equipment to an outlet on a circuit different from that to which the receiver is connected.
- Consult the dealer for technical assistance.

## **Other Warnings**

Electronic devices such as pacemakers, medical equipment, and navigation equipment on an airplane are susceptible to the energy generated from radios such as the CS4000 and CS4001 if they are not adequately shielded. However this is not a portable device because it requires a large battery so those warning normally do not apply.

- If there are signs posted in a hospital or some other health facility that says not to use radios or cell phones, turn off your radio because they might interfere with the sensitive medical equipment.
- If you are on board an aircraft it is recommended you not use this product because of the potential to interfere with the aircraft navigation systems and other electronics on board. Failure to do so without the express permission of the crew could cause you to be detained by the FBI when you disembark from the plane. It also has the potential to cause the plane to crash.
- This radio is heavy. If it falls on your toes it might require you to seek medical help to repair a broken toe.

## **INSTRUCTIONS FOR THE RADIO TECHNICIAN**

### **Connection of Power Cable**

Check whether there is a hole for the power cable on the insulating board. If not, bore the board with the suitable drill bit and fix a rubber grommet on it.

Have the cable pass through the insulating board into the car engine. Connect the red conductor to the positive terminal of the Battery or an equivalent point and connect the black conductor to the negative terminal of the battery or an equivalent point.

Make sure the wires are firmly attached and apply insulation as necessary.

Make sure the power cable is not too tight to allow convenient disassembly of the radio while it is still connected to the power. This will allow you to attach the antenna to the antenna jack without disconnecting the power cable.

### **Installing the Radio in the Vehicle**

For passengers' safety, fix the radio firmly on the fixed bracket so that the radio will not be loosened in case of collision.





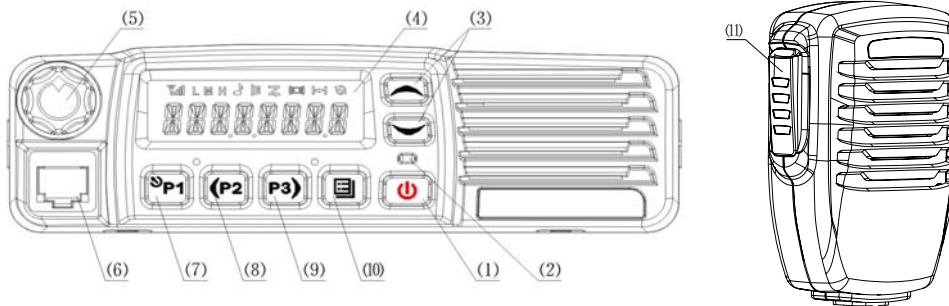

- 1) Mark a position on the instrument panel for the fixed bracket then drill a small hole where it was marked. Install the fixed bracket with the 4 M5\*16 self-tapping screws. (Note: fix the radio at the position convenient for operation and control, and leave an enough space for connection of the power cable and antenna cable.)
- 2) Slide the radio into the fixed bracket and attach it with 4 M4\*10 combination screws Use plus plain washers and spring washers as necessary. Different combinations of holes are selectable to adjust the radio to the proper height and visual angle.
- 3) Connect the antenna and the power cable to the radio.
- 4) Install the microphone hanger at a position easy to use with the 2 M4\*16 self-tapping screws. (The microphone and its cable should be at a position not affecting safe driving.)
- 5) Connect the microphone to the microphone jack on the front panel of the radio and put it on the hanger.

Note: When replacing the protective fuse for the power cable, please use the one of the same specification.

# Radio Overview

## Front Panel



- ( 1 )  power button  
Press this button for a long time (more than 1.5 seconds) to start or close the radio.
- ( 2 ) LED indicator  
The red indicator will light when it transmitting. The green indicator will light when it receiving.  
The indicator will flicker and give an orange light when it receives DTMF, 2Tone, or MDC signal indicating some selective call feature.  
The red indicator flashes in the scanning process.
- ( 3 )  /  button (programming button)
- ( 4 ) LCD display screen  
For details, see “LCD Display”.
- ( 5 ) Volume Control knob  
To be used to adjust volume.
- ( 6 ) Microphone/Programming Interface
- ( 7 )  **P1** button (programming button)
- ( 8 )  **P2** button (programming button)
- ( 9 )  **P3** button (programming button)
- ( 10 )  button (programming button)
- ( 11 ) PTT button (on the hand microphone)  
Press the PTT button first, and then speak to the microphone to transmit your voice to the other radio. Do not press this button if you want to listen to the other some other radio.

## Display Screen

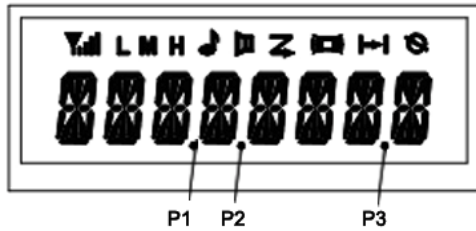

Display	Description
	It means the receiving signal strength. 4 lines mean the strongest signal.
LMH	Transmission power level "L" means the transmission of signal for the radio at the lower power; "M" means the transmission of signal for the radio at the medium power; "H" means the transmission of signal for the radio at the high power;
	Receive Call display The radio receives a selective call/call reminder.
	Monitoring State display
	Scanning State display
	Companding State display
	Talkaround State display
	Interference State display
P1	Decimal Point when displaying frequency
P2	OST State display
P3	Decimal Point when displaying CTCSS tone

## Rear Panel

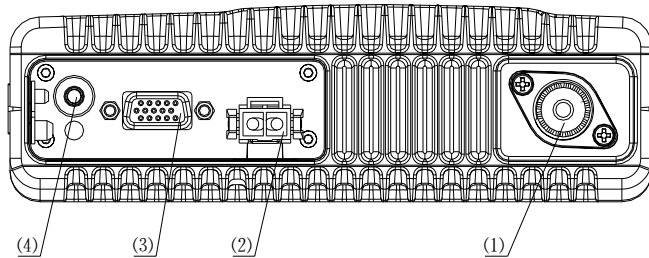

- ( 1 ) Antenna Interface
- ( 2 ) Power Interface
- ( 3 ) 15Pin Extended Serial Interface
- ( 4 ) External Speaker Interface



## **BASIC OPERATION**

### **1. Startup:**

Press the red POWER button for at least 1.5 seconds to start or close the radio.

### **2. Volume**

Press the “MONITOR” or “Squelch” button to listen to the background noise first, and then adjust the volume by turning the volume control knob. Turning the Volume knob to the right (clockwise) increases the volume and turning the Volume knob to the left (counter-clockwise) decreases the volume.

### **3. Channel**

The radio can provide 512 conventional channels (There are totally 16 groups and each has at most 16 channels per group). Press the “CHANNEL UP” or “CHANNEL DOWN” button to select the channel. Press the “GROUP UP” or “GROUP DOWN” button to select the group you require.

### **4. Transmission**







To send a call, press the PTT button and speak to the microphone in the normal voice. Please keep the microphone close to your mouth. After speaking, please release the PTT button.

### **5. Receive**



The radio will return to the receiving state after you release the PTT button.

The radio dealer may have set the QT/DQT/LTR signaling in the program of your radio. When QT/DQT/LTR is programmed, you can only hear calls from the other radios if your QT/DQT/LTR matches the QT/DQT/LTR from the other radio.

## PROGRAMMABLE KEYS

, 
 , 
 , 
 , 
 , 
 
 can be programmed for one of the auxiliary functions. Each key can take on double duty by defining the length of time the key has to be pressed to utilize the extra function. As an example, P2 can be programmed to select the power output if its pressed for less than 1 second and can be programmed to select Talk Around if the key is pressed for greater than 1 second.

Function	Function Meaning
Off	This key not used
Channel Up	Allows the radio-user to navigate up, while in the radio's Menu Mode, or navigate up thru the radio's channels while not in the Menu Mode.
Channel Down	Allows the radio-user to navigate down while in the radio's Menu Mode, or navigate down thru the radio's channels while not in the Menu Mode.
Zone Up	This key will allow the radio-user to navigate up thru the radio's zones while not in the Menu Mode. The purpose of zones is so different radio channels can be grouped together and then when you are using the channel selector to pick a channel you are only looking at channels related to your zone. The Zone number or alias will be near the top left of the display in small characters and the channel number or alias will be below in much larger characters. Every time the key is pressed the next zone is accessed. Zone 0 allows all channels to be accessed. The other zones can access up to 16 channels.
Zone Down	This key will allow the radio-user to navigate down thru the radio's zones while not in the Menu Mode. The purpose of zones is so different radio channels can be grouped together and then when you are using the channel selector to pick a channel you are only looking at channels related to your zone. The Zone number or alias will be near the top left of the display in small characters and the channel number or alias will be below in much larger characters.

	Every time the key is pressed the previous zone is accessed. Zone 0 allows all channels to be accessed. The other zones can access up to 16 channels.
Display Channel Frequency	This is an alternate action key that will change the mode of display between channel frequency and channel name
Display Channel Name	When this key is pressed, it will change the mode of display to the channel name.
Display Mode Switch	This is an alternate action key that switches the mode on the display between “Channel Number”, “Channel Alias”, and “Channel Frequency”.
OST	Allows the radio operator to dynamically select CTCSS/DCS codes for a given channel. Overrides the preset code.
Power Level	This is an alternate action key allows the user to select the power output of the radio from “High Power” to “Mid Power” to “Low Power”. This allows the radio-user to adjust the Transmit Power setting radio-wide unless a particular channel is set to ignore this key. When the radio is in the low power mode, the display on the top line will display “LO”. When the radio is in the mid power mode, the display on the top line will blink the “LO”. When the radio is in the high power mode, the display will be blank where in the other modes there was the “LO”.
Squelch Level	Pressing this button enters the “Squelch Level Adjustment Mode” Press the  /  button to adjust the level and then press the  button to save the selected squelch level and quit this mode.
Key Lock	This is an alternate action key. When the key is first pressed the LCD display will show a picture of a lock near the top right of the display. When the key is pressed again the picture of the lock will disappear. When this feature is active, the programmable keys are locked out as well as the manual programming keys. The channel selector switch still works.
Scan	This allows the radio-user to enter or exit scan mode. The key is only available for

	<p>Scan Lists where the User Programmable field has been enabled. When the scan mode is enabled the display will say "SCAN" in large characters in the bottom middle of the display. The purpose of the scan function is to allow the user to monitor multiple channels and stop at the channel that is active. This would be useful for a supervisor who needs to monitor the activity among different groups of users.</p>
Nuisance Delete	<p>When the radio lands on an unwanted channel during scanning, pressing this key will delete this channel temporarily. When exiting scan mode and entering it again, the channel will be restored. It is possible to delete all the channel except the priority channel.</p>
Voice Comander	<p>This is an alternate action key that enables or disables the Comander option. Comander is a new standard feature in the cellular phone industry and is supported industry-wide. The purpose of Comander is to reduce radio and airway noise, thus enhancing audio clarity. When the Comander option is enabled, a small "p" will appear on the top of the display.</p>
Public Address	<p>You can enable or disable public address function by this key. When enabled, the text "PA" will be displayed on the LCD and the radio can be used as a public address system and your voice will be heard by the surrounding people when you press the PTT switch on the microphone.</p>
Scrambler	<p>This is an alternate action key that enables or disables the Scrambler function. The scrambler makes the voice unintelligible to most people who do not have a compatible radio. This prevents a third party from listening in. When the radio is in the scrambler mode, the display will show a small box with a "T" inside in the top middle of the screen.</p>
Home Channel	<p>This function selects a channel the dealer has preprogrammed. The dealer can preprogram either one channel or two</p>

	<p>channels. If a single channel has been preprogrammed, then pressing the key will select the preprogrammed channel. If the dealer has preprogrammed two channels, then pressing the key will alternate between the two preprogrammed channels. The display will show the channel selected.</p>
Talk Around	<p>This is an alternate action key that selects between talkaround mode and repeater mode. In repeater mode, the radios talk directly to another radio. In repeater mode, the radios talk to the repeater and the repeater in turn talks to another radio. Repeater mode extends the range of the radios. Talkaround mode is useful when the repeater is out of range or the signal strength of the repeater is not sufficient to penetrate inside a building such as when you have a firefighting incident.</p> <p>For this key to work, the transmit and receive frequencies must be different and the key must not be disabled for the channel you are using. When the key is pressed and it goes in the talk around mode, the display will show “Talkarnd Mode” for a few seconds. When the key is pressed and it goes in the repeater mode, the display will show “Repeater Mode” for a few seconds.</p>
VOX	<p>This is an alternative action key that enables or disables VOX. When VOX is enabled, the user only has to speak to transmit. The PTT switch in this mode does not have to be pressed. VOX is useful when the operator of the radio cannot free his hands to use the radio as what might happen if you are driving. When the VOX mode is enabled, the second line of the display will show “Vox”.</p>
Monitor Momentary/Call Cancel	<p>Pressing the Monitor Momentary/Call Cancel key allows monitoring the channel for any voice traffic. The incoming signal has to have the required squelch level before anything can be heard. Releasing the switch puts in back in the normal mode.</p>



	<p>While the key is pressed, the display will show MON on the second line of the display. This key will also cancel the current incoming call.</p> <p>Normally the user will only hear messages with the proper CTCSS or DCS codes. This is to prevent the user from fatigue by hearing all messages sent to everybody. This switch bypasses that protection and allows the user to hear all traffic on that channel as long as the key is pressed.</p>
Monitor/Call Cancel	<p>This is an alternative action key that enables or disables the monitor mode. While in the monitor mode, any voice traffic which has the required squelch level will be heard. While in the monitor mode, the display will show “MON” on the second line of the display. This key will also cancel the current incoming call.</p> <p>Normally the user will only hear messages with the proper CTCSS or DCS codes. This is to prevent the user from fatigue by hearing all messages sent to everybody. This switch bypasses that protection and allows the user to hear all traffic on that channel as long as the radio is in the monitor mode.</p>
Squelch Momentary/Call Cancel	<p>Pressing the “Squelch Off Momentary/Call Cancel” key allows monitoring the channel for any voice traffic. The incoming signal does not to have any signal before anything can be heard. That means if there is no signal you will hear squelch noise. Releasing the key puts it back in the normal mode. While the key is pressed, the display will show MON on the second line of the display. This key will also cancel the current incoming call.</p> <p>By turning off the squelch, the user can hear a weaker signal than if the squelch was already enabled. This is both a diagnostic tool and a feature. If the transmitter from the originating user is weak and does not get past the squelch, then disabling the squelch will allow the user to hear weak signals.</p>

<p>Squelch/Call Cancel</p>	<p>This is an alternative action key that enables or disables the squelch mode. While in the squelch mode, any voice traffic will be heard no matter what the squelch level. That means if there is no signal you will hear squelch noise. While the key is pressed, the display will show “MON” on the second line of the display. This key will also cancel the current incoming call.</p> <p>By turning off the squelch, the user can hear a weaker signal than if the squelch was already enabled. This is both a diagnostic tool and a feature. If the transmitter from the originating user is weak and does not get past the squelch, then disabling the squelch will allow the user to hear weak signals.</p>
<p>Emergency</p>	<p>Pressing the “Emergency” key will cause the radio to transmit an emergency message. The display will show in large letters “EMERGENCY”.</p> <p>Pressing the key designated as “emergency alarm” will cause the radio will go into an emergency mode and depending on the dealer programming, will either generate a local alarm or transmit an alarm to another radio or both.</p> <p>This has a similar function as the Lone Worker mode. The biggest difference is the user must press a key to start this function verses the Lone Worker where not doing something starts the function. This could be used in situations where you want someone to know there is an emergency but talking over the radio might jeopardize the safety of the user.</p>
<p>Cancel Emergency</p>	<p>Pressing the “Cancel Emergency” key will cancel the emergency transmission, generate two beeps, and the cause the “EMERGENCY” on the display to disappear. This key would normally be pressed if the emergency alarm condition is resolved or the emergency alarm key has been pressed by accident.</p>

Radio Call	The Radio Call key is a multifunction key that has the ability to generate Selective Calls, Call Alerts, Radio Check, Kill, and Active. The exact function(s) allowed is determined by the dealer.
Call 1	<p>When the “Call 1” key is pressed, a preprogrammed two tone, DTMF, or MDC page will be sent. If the dealer programmed the radio for side tone, the two tone, DTMF, or MDC page will be heard as it is being transmitted.</p> <p>This is a paging feature that is used to contact individual radio or sometimes to set off certain types of alarming features. When you set it for DTMF, two tone, or MDC the other radio has to be able to receive the corresponding code. Not all radios have the ability to respond to paging.</p>
Call 2	<p>When the “Call 2” key is pressed, a preprogrammed two tone, DTMF, or MDC page will be sent. If the dealer programmed the radio for side tone, the two tone, DTMF, or MDC page will be heard as it is being transmitted.</p> <p>This is a paging feature that is used to contact individual radio or sometimes to set off certain types of alarming features. When you set it for DTMF, two tone, or MDC the other radio has to be able to receive the corresponding code. Not all radios have the ability to respond to paging.</p>
Call 3	<p>When the “Call 3” key is pressed, a preprogrammed two tone, DTMF, or MDC page will be sent. If the dealer programmed the radio for side tone, the two tone, DTMF, or MDC page will be heard as it is being transmitted.</p> <p>This is a paging feature that is used to contact individual radio or sometimes to set off certain types of alarming features. When you set it for DTMF, two tone, or MDC the other radio has to be able to receive the corresponding code. Not all radios have the ability to respond to</p>









	<p>paging.</p>
Call 4	<p>When the “Call 4” key is pressed, a preprogrammed two tone, DTMF, or MDC page will be sent. If the dealer programmed the radio for side tone, the two tone, DTMF, or MDC page will be heard as it is being transmitted.</p> <p>This is a paging feature that is used to contact individual radio or sometimes to set off certain types of alarming features. When you set it for DTMF, two tone, or MDC the other radio has to be able to receive the corresponding code. Not all radios have the ability to respond to paging.</p>
Horn Alert	<p>Enables or disables Horn Alert function. When enabled, an external DTMF or Two Tone code can be used to set of the Horn Alert.</p>
Lease Time	<p>When the “Lease Time” key is pressed, the remaining time the radio can be used will be displayed. The radio will show the number of days, the number of hours, and the number of minutes. Pressing any other key will erase the remaining time from the display.</p>
Lone Work	<p>This is an alternative key that enables or disables the Lone Work mode. When the Lone Work mode is enabled, a single beep will be heard and the top line of the display will show “SVC”. When the lone work mode is disabled, a double beep will be heard and the “SVC” will be erased from the display. When the radio goes into the emergency mode, the display will show in large letters, “EMERGENCY”. The only way to get out of the emergency mode is to turn off the power.</p> <p>The purpose of this function is to call for help if the person holding this radio does not press a key on the radio every so often. Once the radio is set for the Lone Worker mode, a timeout timer is started. At the end of this time an alarm on the radio will sound telling the user to press either the Lone Worker reset key or any key,</p>

	depending how the unit is preprogrammed. If the user does not press the appropriate key soon after the radio starts to alarm, the radio will go into an emergency mode and depending on the dealer programming, will either generate a local alarm or transmit an alarm to another radio or both.
In/Out Speaker	Enables or disables the speaker for purposes of generating an alarm. When enabled, an external DTMF or Two Tone code can be used to set of the Speaker Alert.
Scan List Edit	This allows the radio-user to edit a Scan List. Scan List editing is only available for Scan Lists where the User Programmable field has been enabled
GPS Information	It's used to look over the GPS information with GPS mobile.
Vox Level	This key is used to adjust the level of the VOX. Level 1 is the least sensitive and Level 10 is the most sensitive. Pressing this button enters the "Vox Level Adjustment Mode" Press the  /  button to adjust the level and then press the  button to save the selected Vox level and quit this mode.
Missed Call	The Missed calls key is used to display the list of missed calls. As an example, you leave your radio, and while you were gone you received three calls.. When you come back you can use the missed calls key to see who have called you and then call those parties back. This feature is not currently supported.
GPS Auto Tx	This feature allow the users to change the mode of the GPS Auto Tx . An alert tone heard will enable the feature, and two alert tone heard will disable the feature

## CHANGING THE PARAMETERS FROM THE KEYPAD

### Send Selective Call







- A. Press “Menu Selection/Enter” button to enter the menu mode.
- B. Press  /  button until “RADIOCAL”.
- C. Press  button to select “SEL CALL”.
- D. Press  /  button until the required call list appears.
- E. Press “PTT” button to send the selective call.
- F. Press “PTT” button and speak to the microphone in normal voice. Please keep the microphone about 3 to 4 cm far from your mouth. After speaking, please loosen the “PTT”.
- G. Press  button to return to the previous operation.

### Receive Selective Call

Receiving a selective call, you will hear the prompt tone and find the orange indicator flashes.  icon flashes and the calling party’s ID code or name displays. Press PPT button for callback.







### Call Prompt

After the radio receives the call prompt, the prompt tone will sound and the orange indicator flicker.  icon flashes and the calling party’s ID code or name shows until someone answers. Press the “PTT” button for callback or other buttons for cancellation.

- A. Press “Menu Selection/Enter” button to enter the menu mode.
- B. Press  /  button until “RADIOCAL”.
- C. Press  button to select “CALL ALT”.
- D. Press  /  button until the required call list is showed.
- E. Press “PTT” button to utter the selective call.
- F. After calling, press  button to return the previous operation.

### Select Group

According to the setup of the communication network, the vehicle mounted radio can be distributed to different groups. Select the proper group to realize calling with the vehicle mounted radio of different groups. Select the group through menu as follows:





- A. Press the “Menu Selection/Enter” button to enter the menu mode.
- B. Press  /  button until “ZONE”.
- C. Press  button for selection.
- D. Press  /  button until the group name you require is appeared.
- E. Press  button for selection.

Select the group through “GROUP UP” or “GROUP DOWN”.

### Talkaround

In the communication network, you can expand communication range through the repeater, but when the mobile radio is out of the communication range, you can connect with other radio in the talkaround method. The talkaround function can be showed by . Select talkaround by menu as follows:

- A. Press the “Menu Selection/Enter” button to enter the menu mode.







- B. Press  button until “RPTRTALK”.
- C. Press  button for selection.
- D. Press  button until “REPEATE” or “TALKRND”.
- E. Press  button for confirmation.

Switch the talkaround or repeater mode through “talkaround”.

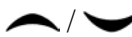
### Miscellaneous Items

The miscellaneous items can help you customize some setups of the radio.

The operating steps go as follows:

- A. Press the “Menu Selection/Enter” button to enter the menu mode.
- B. Press  button until “UTILITY”.
- C. Press  button for selection.
- D. Press  button until the items you require are showed.
- E. Press  button for confirmation. The radio will show the current setup.
- F. Press  button to show all items that can be set with this item.
- G. Press  button to select this setup.
- H. Press  button to return to the previous operation.

Change the setup items in the following table as per the previous steps.

Items	Selectable Setups	Functions
Squelch Level "SQL LEV "	SQL 0 ~ 9	Change the squelch level of the radio.
Transmission Power "PWR LEV "	"PWR LOW " "PWR MID ", "PWR HI "	Select transmission power among high, medium and low levels.
VOX Level "VOX LEV "	VOX 0 ~ 9	Change the VOX level of the radio.
Backlight "BACK LED"	"BLED OFF" "BLED ON " "BL AUTO "	Select among such modes of backlight as “turnoff”, “normal turn-on” or “auto”.
MCU software version display "SOFT VER"	..... Eg. “R01.00”	Show the software version.





### Scan

In order to receive the calls from many channels, the radio can be programmed to scan these channels. At most there are 16 channels in each scan list. Each channel can use a scan list together with others or alone.

### Start/Close Scan Function

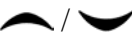
You can press “SCAN” button directly from the menu to activate the scan function. When the scan function is started,  icon and your channel will display at the same time. In the scan state, the red indicator will flicker. When the scan is stopped, the indicator will stop flickering. During the period from the scan state the menu mode, the radio will stop scanning. After the menu is quitted, the scanning will go on.

### Enter the scan state through menu mode

- A. Press the “Menu Selection/Enter” button to enter the menu mode.
- B. Press  button until “SYS SCAN”.
- C. Press  button for selection.
- D. Press  button until “SCAN ON?” or “SCAN OF?”
- E. Press  button for confirmation.

**Use the scan button**

- A. Press “SCAN” button to activate the scan function.
- B. Press “SCAN” button again to close the scan function.







**Cancel Noise Channel**

If a channel continuously produces noise or interference, press the “Nuisance Delete” button to cancel this channel from the scan list temporarily.









Note: the priority channel and the last one in the scan list cannot be canceled.

**Edit Scan List**

Press the “Menu Selection/Enter” button to enter the menu mode.

- A. Press  button until “PROG LST”.
- B. Press  button to select “SCAN LIST”.
- C. Press  button until “ADD LST?” or “DEL LST?”.
- D. Press  button for selection.
- E. Press  button until the channel you want to add or cancel displays.
- F. Press  button to complete operation and the show “CHN SAVE” or “CHN DEL”.
- G. Press  button to return to the previous operation.

**Set Priority Channel**

- A. Press the “Menu Selection/Enter” button to enter the menu mode.
- B. Press  button until “PROG LST”.
- C. Press  button to select “SCAN LIST”.
- D. Press  button until “ED PRIO?”.
- E. Press  button for selection.
- F. Press  button until “PRIO#1?” or “PRIO#2?”.
- G. Press  button to select the type of the required priority channel.  
For example, in Step 7, the type of priority channel is “DES?”. Press  button to select the required priority channel.
- H. Press  button to complete operation.
- I. Press  button to return to the previous operation.

**OST**

In a certain specific channel, you can revise the QT/DQT encoding setup of current channel. The operating steps go as follows:

- A. Press the “OST” button to enter the OST menu mode.
- B. Press  button until the QT/DQT code/decode shows.







- C. Press  button to select quitting.

Note:

- Where the OST backup function is selected, the radio will save the OST code of each channel even if the channel is changed or the machine is shut down.
- In the OST state, the LCD of the vehicle mounted radio and P2 icon will display.
- In the OST state, press “OST” button again and the QT/DQT of the radio will return to the original position.

### **GPS Information View**

If the radio starts the GPS function, you can view the current GPS information. The specific operating steps go as follows:

- A. Press “GPS Information View” button to enter the GPS information display mode.
- B. Press  /  button until the items you require displays.
- C. Press  button for selection.
- D. Press  /  button for page up of the following content.
- E. Press  button to return to the previous operation.

The specific content can be shown as follows:

1. Positioning star number: “STAR NUM”
2. Longitude “LONGITUD”
3. Latitude “LATITUDE”
4. Altitude “ALTITUDE”
5. Speed “SPEED”
6. Time “TIME”
- 7.

### **Wired Clone Mode**

Once the Wired Clone Mode is entered, the only way to exit that mode is to turn off and on the power of the radio. The Wired Clone Mode can be enabled or disabled by the PC Program Software.

The operating steps go as follows:

- 1 Press [P1] and [P2] on the host simultaneously while turning on the power. The host display will show “CLONE” and enter the clone mode. If such a mode is not allowed, it will enter the user mode.
- 2 Connect the two radios together with the cloning cable and then turn on the power for the destination radio.
- 3 Press the [P4] button on the host to start the clone. At this time the red indicator will light, the Display will say “CLONING” and the data will be transmitted to the destination radio from the host. During the period when the destination is receiving the data, it will show “PROGRAM” and the green indicator light will be illuminated. After completion the host will show “SUCCESS” and the destination radio will automatically restart.
- 4 Press the [P4] button and the host will return to the clone mode. To program another radio start from Step 2.